

## Chapter 5

### Conductive studies on PZT thin film and their application in asymmetric nematic liquid crystal cells

#### 5.1 Preface

Thin film of PZT ( lead zirconium titanate oxide [ $(\text{Pb}(\text{Zr}_{0.47}\text{Ti}_{0.53})\text{O}_3)$ ] are of great interest for their application in non volatile memories, then, the interest in physical and electric properties of such materials has been considerable in the last 10 years [1,2], moreover, the problem, associated with application of ferroelectric materials such as polarisation fatigue, ageing and field and frequency dependence of the piezoelectric, elastic and dielectric properties, generated intensive research of the fundamental properties of ferroelectrics [3]. One of main aspect in understanding the behaviour of ferroelectric films is the interaction between the ferroelectric film and the material used as substrate. In fact, the material used for bottom electrode can play an important role in determining the

characteristics of ferroelectric films. Platinum is the most popular material as the bottom electrode for ferroelectric thin films because its good resistivity to oxidation. Otherwise, conducting oxide electrodes such as  $\text{RuO}_2$  [4],  $\text{IrO}_2$  [5], or  $\text{SrRuO}_3$  [6] are also used as electrode to compensate the oxygen vacancies to eliminate the polarisation fatigue of ferroelectric capacitor [7].

In the present work has been studied the conductive properties of a PZT ( $\text{Pb}(\text{Zr}_{0.47}\text{Ti}_{0.53})\text{O}_3$ ) thin film obtained by sol-gel route for different bottom electrode (copper and ITO).

In a second step we have provided to the application of PZT thin film in asymmetric nematic liquid crystal cells. The ferroelectric properties of PZT allow us to obtain a polar reorientation in the liquid crystal films in the way as the ions migration in the previously used oxides. In the PZT case we obtain a considerable improvement in term of contrast as well as of response time.

## 5.2 Sol-gel synthesis

Lead Zirconate Titanate (PZT) thin films, with stoichiometric ratios indicated in the formula  $\text{PbZr}_{0.53}\text{Ti}_{0.47}\text{O}_3$  were obtained by hybrid

(carboxylate and alkoxides)<sup>1</sup> sol gel route and spin coating deposition of the obtained mother solution on ITO (indium tin oxide)-glass substrate (sheet resistivity  $\rho_s = 20 \Omega/\square$ , Unaxis GmbH).

Many sol gel synthesis can be found in literature<sup>2-24</sup>, some based on the same starting materials and different processes and some which use less common materials. Anyway, among the different sol gel synthesis<sup>1-23</sup>, the procedure used in this work to synthesise the PZT has been deduced by modifying some particular aspect of the synthesis process shown before in previously works<sup>25-27</sup>.

The reagents (all supplied by Sigma-Aldrich) used are Lead(II) acetate trihydrate ( $\text{Pb}(\text{CH}_3\text{COO})_2 \cdot 3\text{H}_2\text{O}$ , 99.999 %), Zirconium(IV) propoxide solution ( $\text{Zr}(\text{C}_3\text{H}_7\text{O})_4$ , 70 wt. % in 1-propanol), Titanium(IV) isopropoxide ( $\text{Ti}[(\text{CH}_3)_2\text{CHO}]_4$ , 99.999 %) Acetic acid glacial ( $\text{CH}_3\text{COOH}$ , 99.99+ %), n-Propanol anhydrous ( $\text{CH}_3\text{CH}_2\text{CH}_2\text{OH}$ , 99.7%), Ethylene glycol anhydrous ( $\text{HOCH}_2\text{CH}_2\text{OH}$ , 99.8%).

In this work, the synthesis of the stock solution has been performed in an “umidity free” Glove Box in Argon atmosphere. In order to obtain stable mother solution, 10.43 g of  $\text{Pb}(\text{CH}_3\text{COO})_2 \cdot 3\text{H}_2\text{O}$  have been dissolved in  $\text{CH}_3\text{COOH}$  by stirring and heating the solution up to 80°C for fifteen minutes. The chosen amount of  $\text{Pb}(\text{CH}_3\text{COO})_2 \cdot 3\text{H}_2\text{O}$  has been calculated

in such a way to obtain a 10% excess in mole of lead, which compensate the lead loss (as PbO) which occurs during the process. The amount of acetic acid has been chosen in order to have its mol number twice the sum of the mol number of lead, zirconium and titanium.

After two minutes at 80 °C, the heater was set at 70°C and when the solution was cooled down to the latter temperature, the stoichiometric amount of  $Zr(C_3H_7O)_4$  solution, have been added. As it was already reported<sup>5</sup>, by adding zirconium butoxide, the temperature increases of  $\approx 10^\circ C$ .

Later on, after fifteen minutes, when the temperature is again 70°C and all the particles eventually formed are dissolved,  $Ti[(CH_3)_2CHO]_4$ , in its stoichiometric ratio, was added. The resulting solution has been stirred for one hour at 70°C, for another hour on a cold stirrer (room temperature) and for another hour on a room temperature stage without stirrer.

When the solution is cooled down to room temperature,  $CH_3COOH$  have been added and the solution has been left to stir for 15 minutes. The amount of acetic acid used, in this work, is such that the total mol number of the acetic acid present in solution is twenty-five times the titanium mol number<sup>27</sup>. The addition of the acetic acid, at this step, needs to slow down the reaction which otherwise occurs when the n-propanol will be

added, with the consequent formation of a white precipitate<sup>25,27</sup>.

At this point 23.10 g of  $\text{CH}_3\text{CH}_2\text{CH}_2\text{OH}$  have been added and again stirred for others 15 minutes.

At this time, 1.16 g of  $\text{HOCH}_2\text{CH}_2\text{OH}$  have been added in order to obtain homogenous film (1ml of  $\text{HOCH}_2\text{CH}_2\text{OH}$  for each 10 g  $\text{Pb}(\text{CH}_3\text{COO})_2 \cdot 3\text{H}_2\text{O}$ )<sup>25</sup> and then the solution has been sealed with parafilm and left to stir for one night.

Finally, the solution has been removed from the glovebox and 9 g of bidistilled water have been added before the spin coating, to have a resulting concentration of 0.38(4) mol/l for the final  $\text{PbZr}_{0.53}\text{Ti}_{0.47}\text{O}_3$  solution.

The ITO glasses substrate have been previously ultrasonically cleaned<sup>28</sup> and an SC10 CaLCTec s.r.l. spin coater has been used for the deposition. PZT thin films have been obtained at 1200 rpm 25. Such films, have been placed on a hot plate for 5 minutes at 300°C.

Later on, the films were subjected, for an hour, to different single thermal treatment in an oven in temperature range between 100 °C and 800 °C, each one separated by 100°C step.

### 5.3 Conductivity on PZT films and calorimetric characterisation

As it regard the conductive properties of the PZT films, these have been studied using the setup described in figure 5.3.1, in this case, an electrode has been directly placed in contact to the sample and the current flowing through the PZT film is withdrawn from a resistor connected in series to the upper electrode. Such measurement has been effected for different conductive layer used as substratum for the PZT, in particular copper and ITO (indium-pond oxide) have been used. In figure 5.3.2 *a* and *b* are showed the current measurements on a PZT film deposited on a copper substrate and annealed at 600°C when a triangular wave is applied to the circuit in figure 5.3.1. They are two remarkable finding: one of them is the strongly frequency dependence of the current flowing through the PZT film; in fact the current measured at 2.5 mHz (fig. 5.3*a*) is sensitively greater than the current measured at 10Hz (fig. 5.3*b*), the other one is the semiconductor behaviour of this system, in fact the current flowing through the PZT film is cut for negative polarity of the applied voltage.

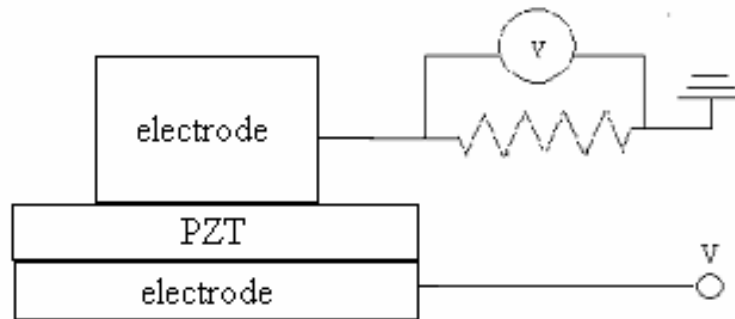

*Fig.5.3.1) conductivity measurement setup*

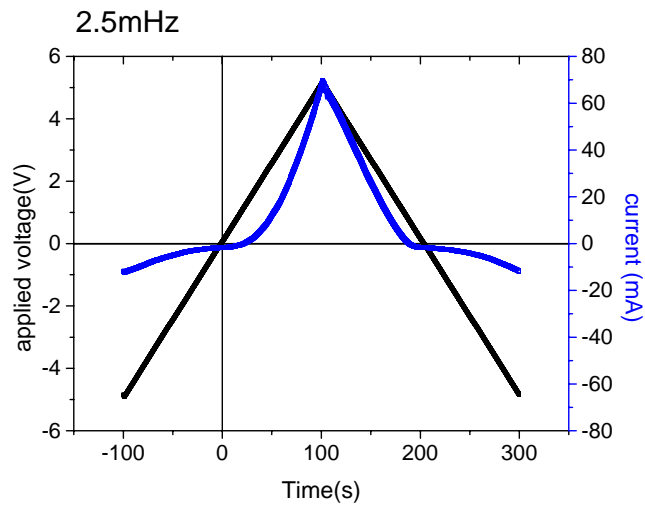

a

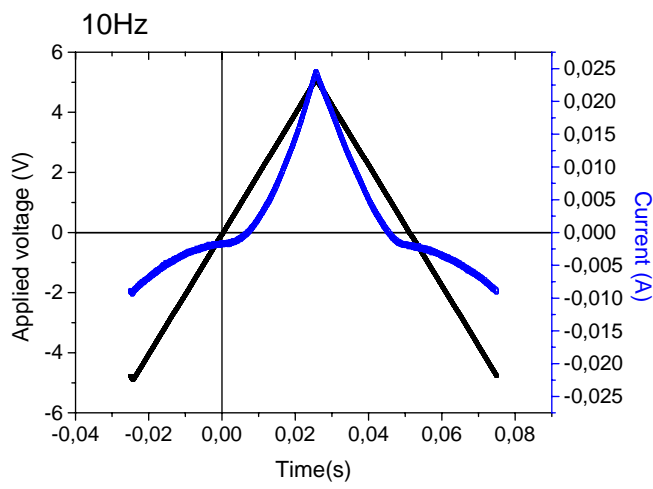

b

Fig.5.3.2) Current flowing through a PZT film when a triangular wave (the black curve) is applied. a: frequency of the applied voltage 2.5mHz, b: 10mHz.



By plotting the current versus the applied voltage (fig. 5.3.3) we obtain a diode like curve in which is well appreciable an hysteresis in the positive side of the graphic.

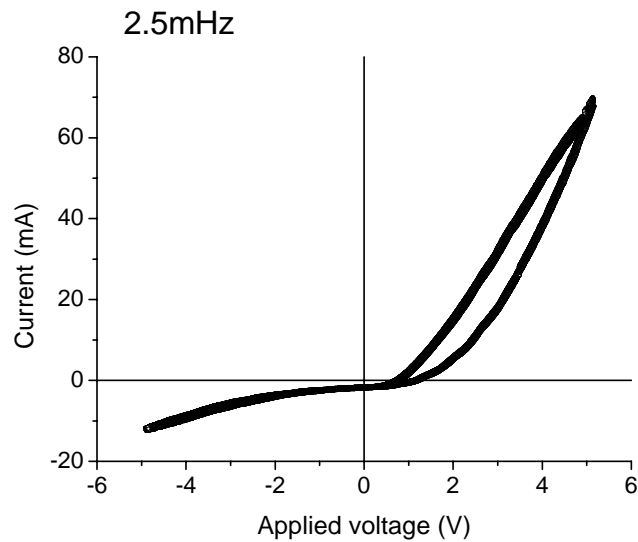

*Fig.5.3.3) Plot current – voltage.*

In order to obtain more information about the accumulating charge process that is responsible of the hysteresis, the increasing side (one half of period) has been analysed separately for a series of

frequency values going from 2.5mHz to 250Hz in step of one order of magnitude and all of these plots has been fitted with the function

$$I(T, V) = a + bV^m \quad 5.3.1)$$

connecting the current intensity  $I$  to the period  $T$ , that should enter the parameter  $b$  ( $a$  gives just a shift of zero and it is not interesting), and the applied voltage  $V$ , while  $m$  is a constant. For any plot a very good agreement with the experimental curve has been obtained. In figure 5.3.4a and 5.3.4b are reported respectively the plots for lowest frequency value of the applied voltage (2.5mHz) and the and the higher one (250Hz) both fitted with the function 5.3.1.

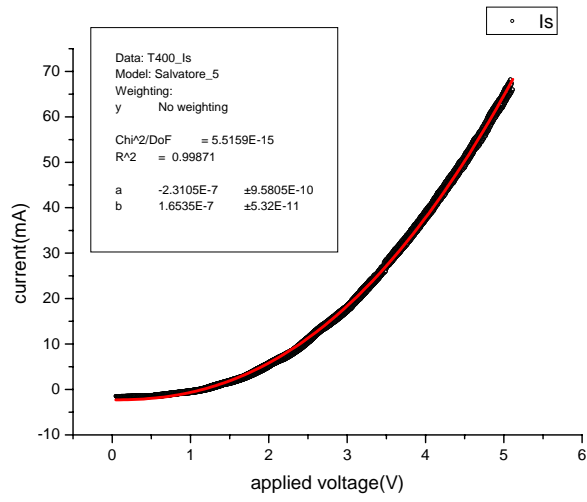

*a*

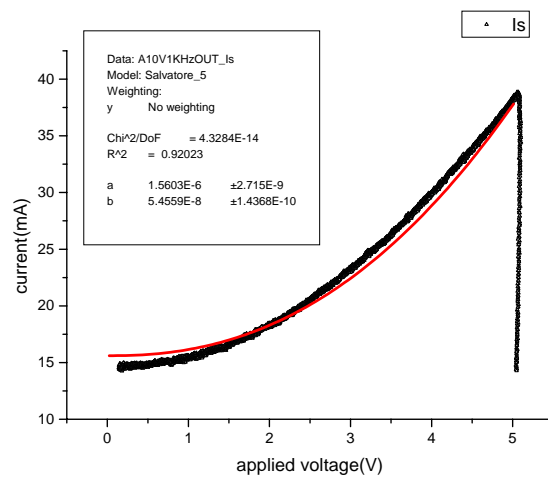

*b*

*fig.5.3.4) Current – voltage plot of the increasing ramp of the applied voltage at 2.5mHz (a) and 250Hz (b).*

In order to obtain the the relation between  $b$  and  $T$  the fitted values of the parameter  $b$  has been plotted respect to  $T$  (see fig. 5.3.5) and a good fitting function (equation 5.3.2) has been founded

$$b(T) = \alpha + \beta T^\gamma \quad (5.3.2)$$

where  $\alpha=4.7512 \cdot 10^{-8}$ ,  $\beta=2.5969 \cdot 10^{-8}$ ,  $\gamma=0.25402$ .

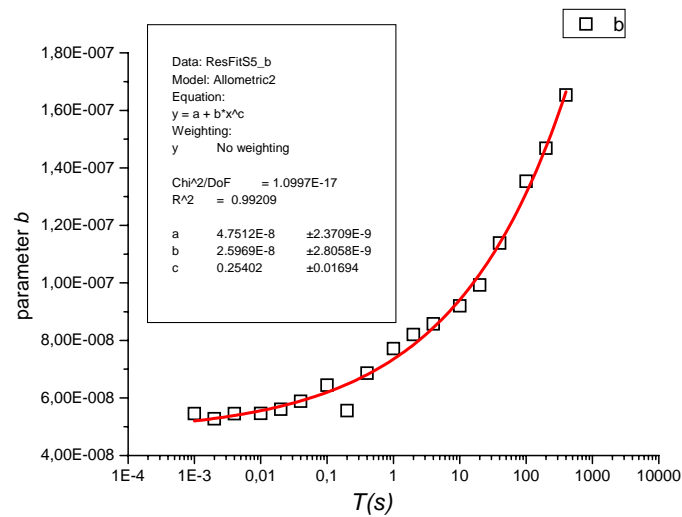

fig.5.3.5) plot of parameter  $b$  versus  $T$ .

Using the function (5.3.1) one could find the charge  $Q$

$$Q = \int_0^{T/4} I dt = \frac{1}{v} \int_0^{V_0} (a + bV^m) dV = \frac{T}{4V_0} \left( aV_0 + \frac{b}{m+1} V_0^{m+1} \right) = \left( \frac{a}{4} + \frac{bV_0^m}{4(m+1)} \right) T \quad (5.3.3)$$

where we used the fact that for the triangular voltage one has  $V(t) = vt$ ,  $dt = \frac{1}{v} dV$ , and  $x = \alpha V$ . As for  $t = T/4 \Rightarrow V = V_0$ , we have  $\frac{1}{v} = \frac{T}{4V_0}$ .

Now, using the function (5.3.2), one gets

$$Q = \frac{T}{4} \left( a + (\alpha + \beta T^\gamma) \frac{V_0^m}{m+1} \right) = pT + qT^{\gamma+1} \quad (5.3.4)$$

where  $p \equiv \frac{a}{4} + \frac{\alpha V_0^m}{m+1}$  and  $q \equiv \frac{\beta V_0^m}{m+1}$ .

Of course, the values  $p$  and  $q$  computed with  $a$ ,  $\alpha$ ,  $\beta$ ,  $m$ ,  $V_0$  should be consistent only with the charge passed in one quarter of a period, not with the accumulated hysteresis charge, but the order of magnitude should be the same.

Finally we have used the fitting function:

$$Q = pT + qT^{1.254} \quad 5.3.5)$$

to fit the plot of the accumulated charge in function of the period ( that is the inclusive area of the hysteresis calculated for different values of the frequency of the applied voltage) and the agreement is excellent (see figure 5.3.6).

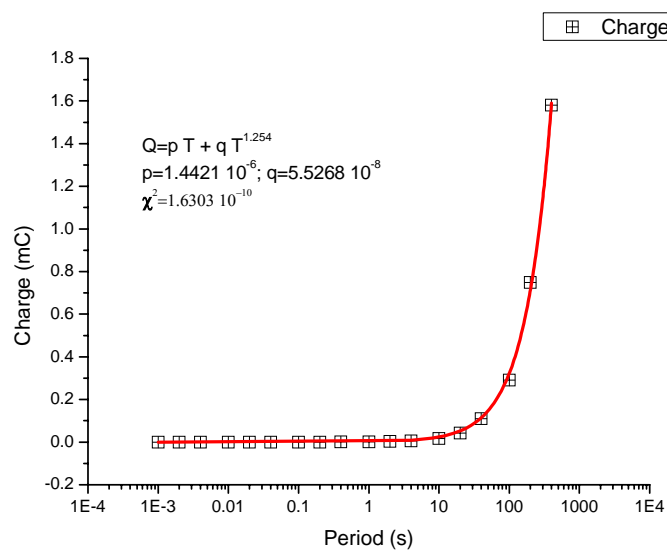
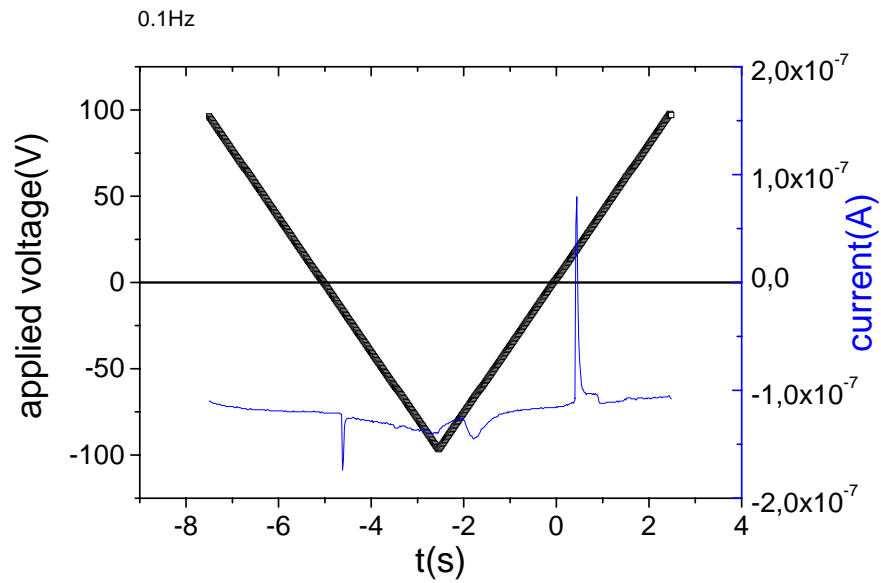

fig.5.3.6) Charge in function of the period.

A completely different behaviour is observed when the PZT film is deposited on an ITO substrate. In this case the current flowing through the PZT is very smaller and show two peak typical of a repolarisation current in a ferroelectric. (see figure 5.3.7)



*Fig.5.3.7) Current flowing through a PZT film deposited on an ITO substrate when a triangular wave (the black curve) is applied.*

In order to obtain information about the transition temperature to the ferroelectric phase of the PZT, a calorimetric characterisation has been effected on the sample deposited on ITO substrate. In figure 5.3.8 it is shown the variation of the specific heat for a temperature range going from 650 to 950°K. The two curve in the upper side of the graphic are referred to two consecutive measurement effected on a monolayer sample, while the curve in the down side is referred to a sample having 5 spin coating depositions. In each of the curves has been in relief an esothermic peak around 875°K (600°C) demonstrating that a crystallisation process occur for this temperature value.



$\Delta C_p$  PZT-ITO

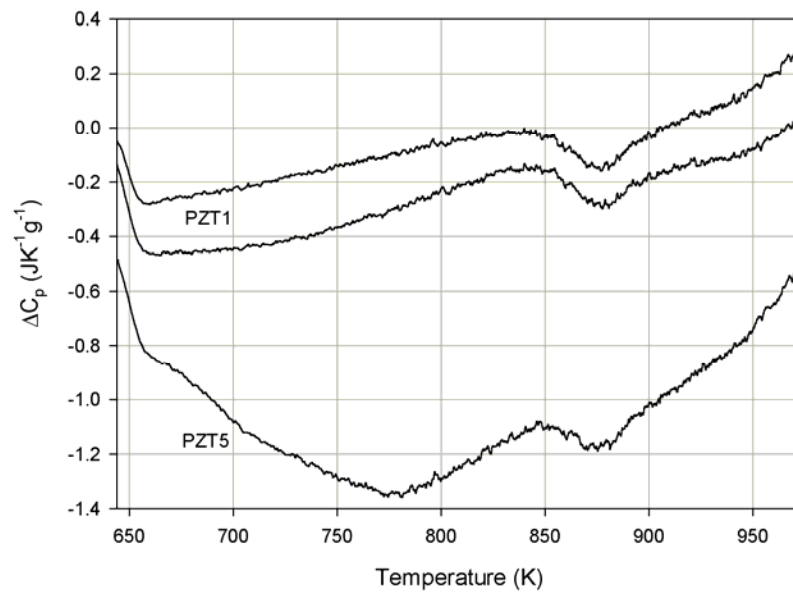
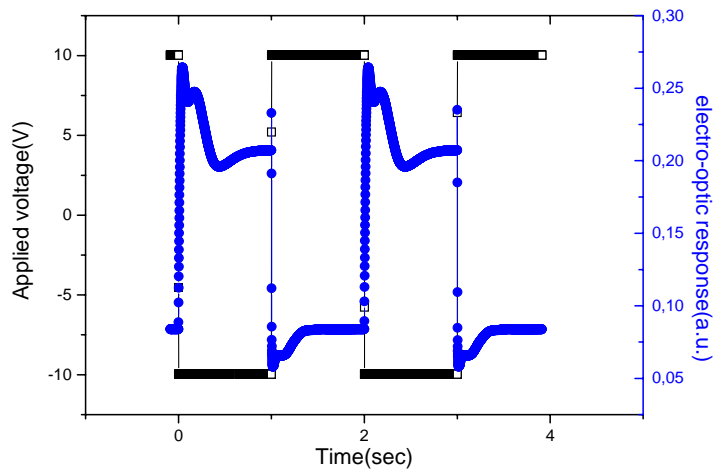

fig.5.3.8) Calorimetric measurements.

## 5.4 Electro-optical response

The reported data shown the electro optic behaviour of NLC cells containing PZT film with different annealing temperatures (100°C and 600°C). For all of the cells the electro optic response appear in opposition phase respect to the applied square voltage but a real rectification effect is visible only in case of high annealing temperatures. The best results has been obtained with the cell containing the PZT film annealed 600°C, on the other side a very small effect is present in the case of a cells containing a PZT film annealed at 100°C. (see fig.5.4.1).



(a)

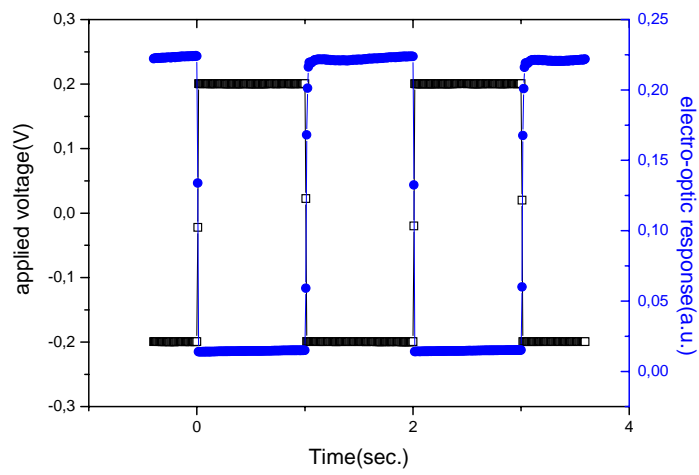

(b)

Fig.5.4.1) Electro-optic response of a NLC cells containing a PZT layer annealed at 100°C (a), 600°C (b)

## Conclusions

As it regard the conductivity measurement of the PZT film deposited on a copper substrate it can be said, first of all, that the  $V^m$  dependence is quite known in physics. For an Ohmic resistor the value of  $m$  is 1, of course, but there is the so called 3/2 law in semiconductor physics (i.e.  $m=3/2$ ). Here  $m \approx 7/3$ .

The idea is that the  $V^{7/3}$  law is linked to the transport mechanism across the PZT film. The parameter  $b$  is linked to the carrier density and it should be dependent on the liberation of new carriers (with low mobility, i.e. ions, presumably  $Cu^+$  or  $Cu^{2+}$ ) in time.

The liberation and the reabsorption of carriers is a slow process connected also to the internal field. For each value of the voltage across the sample there should be a characteristic time for free carriers to reach the new equilibrium value. If the sweeping time (that is  $T/4$ ) of the voltage is smaller than the characteristic time, the carrier concentration does not reach saturation. Contrary, decreasing the voltage (the next  $1/4$  of a period) the accumulated charge carriers do not have enough time to diminish toward the equilibrium value, so the decreasing of the current does not follow the

same path as the increasing current and this asymmetry creates the hysteresis charge.

Probably, performing Hall measurements for several voltages and for a long time (for instance, acquiring the information each 1 minute for 1 hour or more) one could get the sign and the profile of the carrier density within the film.

The other main objective founded in this work has been to test a ferroelectric materials as active substrate for asymmetric NLC cells. An experimental evidence of an internal field acting with different intensity for opposite polarity of external voltage can be tacked from these data. In particular, in the electro optical response, the molecular reorientation result inhibited during the cathodic polarisation. These behaviour can be ascribed to the ITO – PZT and PZT – LC interfaces interaction which is responsible of a favourite orientation of the PZT dipoles and then of a polar response of the liquid crystal layer. One of the next aim of the present research is an accurate analysis of the interlayer phenomena acting at the different interface of the cells, so that to have a complete explanation of the observed polarity sensitive effect.

## References.

- [1] C.T. Lin, B.W. Scanlan, J.D. Mcneill, J.S. Webb and L. Li, *S. Mater. Res.*, 7(9), 2546 (1992)
- [2] S.S. Dana, K.F. Etzold and S. Clabes, *J. Appl. Phys.*, 69(8), 4398 (1991)
- [3] D. Damjanovic: Ferroelectric, dielectric and piezoelectric properties of ferroelectric thin films and ceramics. Laboratory of ceramics, Departement of Material Scienze, Swiss Federal Institute of Tecnology-EPFL, 1015 Lausanne, Switzerland (5 May 1998)
- [4] Asano G, Morioka H and Funakubo H 2003 *Appl. Phys. Lett.* 835506
- [5] Kang B S, Kim D S and Jo J Y et al 2004 *Appl. Phys. Lett.* 843127
- [6] Aggarwal S, Jenkins I G and Nagarag B et al 1999 *Appl. Phys. Lett.* 751787
- [7] JLA Ze, Ren Tian-Ling, LIU Tian-Zhi, HU Hong, ZHANG Zhi-Gang, XIE Dan, LIU Li-Tian, 2006 *Chin. Phys. Lett.* 100084.

## **Special tanks**

*Prof. Andrei Ionescu*

*Prof. Anca Alexe Ionescu*

*Prof. Enzo azzanelli*

*Dr. Marco Castriota*

*Dr. Alfredo Pane*

*Dr. Tiziana Barone*

*Dr. Giuseppe De santo*

### **And to all of the licryl group members:**

*Thanks for the trust that has been given me, for the opportunity of cultural and human growth that has been offered me, this experience will represent one of the most important and meaningful stones in my life.*

